

ODECA

IRD

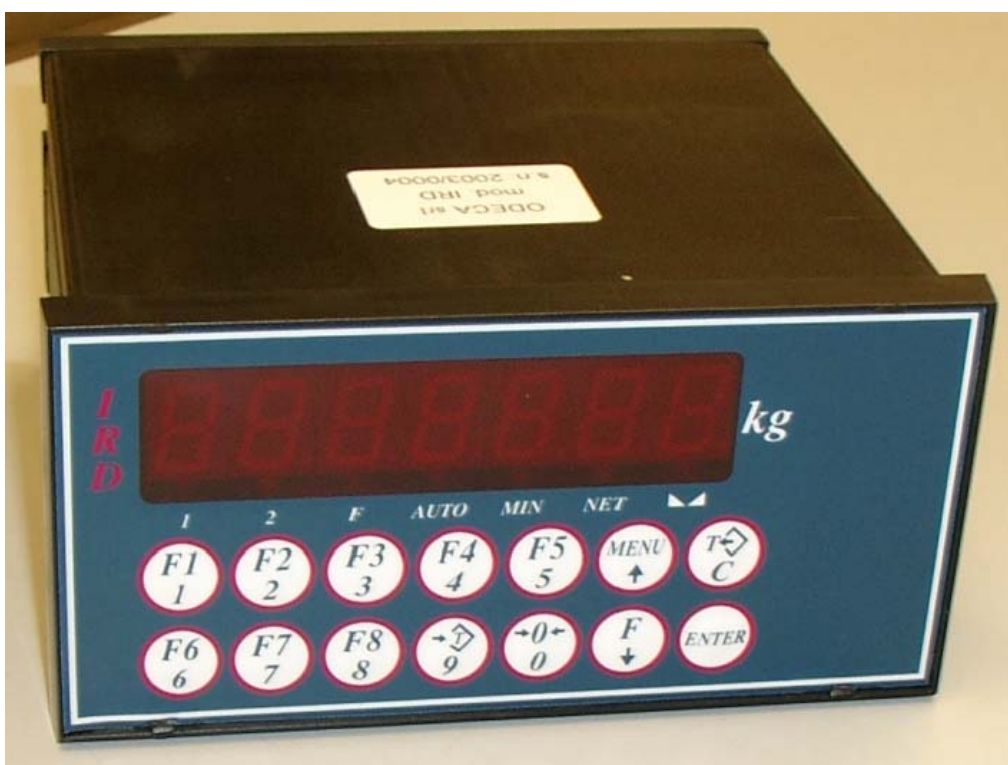

CE

TECHNICAL GUIDE

TECHNICAL CHARACTERISTIC

Power	230 Vac 50/60 Hz
Consumption	15 VA
Working temperature	-10°C ÷ +40°C
Storage temperature	-20°C ÷ +50°C
Weight display	Red led display (height 14 mm)
Led	N° 7 led indicators
Keyboard	14 keys with buzzer
Dimensions	144 mm x 72 mm x120 mm (l x h x p) (DIN43700)
Assembly	Panel assembly (hole dimensions 139 mm x 67 mm)
Protection rate	IP54
Load cell excitation	5 Vcc / 120mA (max 8 load cells 350Ω)
Input Sensitivà	0.02 µV min.
Linearity	< 0.01% R.O.
Temperature deviation	< 0.0003% R.O. / °C
Internal resolution	24 bit
Max display resolution	60000 div.
Misuring field	From -3.9 mV/V to +3.9 mV/V
Digital filter	From 0.2 Hz to 50 Hz
Output	N° 6 relè max 115Vac/30Vdc, 0.5 A
Input	N° 8 digital input 12Vcc/24Vcc PNP
Serial output (n° 2)	COM1: Rs232c half duplex COM2: Rs422/Rs485 half duplex.
Max cable lenght	15m (Rs232c) and 1000m (Rs422 e Rs485)
Serial protocol	ASCII, Alfapanel, EPSON, Modbus
Baud rate	1200, 2400, 4800, 9600, 19200, 38400, 115000
Clock / calendar	On board
Analog output	0 ÷ 10 V / 0 ÷ 5 V / 0 ÷ 20 mA / 4 ÷ 20 mA
Resolution	16 bits
Calibration	Through keyboard
impedance	Volt: min. 10KΩ Ampere: max. 300Ω
Linearity	0.03% R.O.
Temperature deviation	0.001% R.O. / °C
Compliance	EN50081-1, EN50082-2, EN61010-1, EN45501

SECTION 1 : INSTALLATION

- The hole in the panel should have these dimensions : mm 139x mm 67
- The depth is 135 mm
- The load cell cable should have a length of 140mt/mm2.

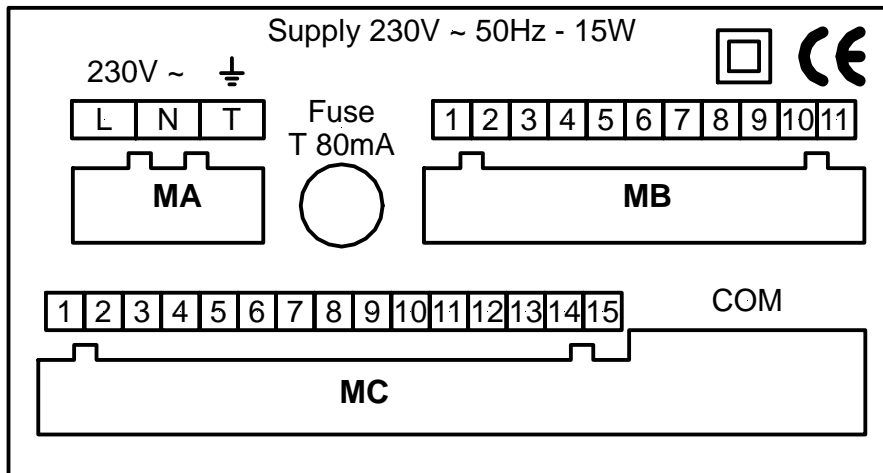

POWER SUPPLY

Power supply : 230V ~ 50/60 Hz 15W
 Fuse : T 80mA

CONNECTION : **MA** - 3 PIN step 10 mm

L. LINE
 N NEUTRAL
 T GROUND

LOAD CELL CONNECTION

- The load cell cable should not be canalize with other cables.
- To IRD can be connected max. 8 load cell 350 ohm . The power supply of the load cells is 5 Vdc.
 The sensitività of the load cells can be from 1 mV/V to 3.9 mV/V.
 The load cell cable is to be connected to terminal board MC from 1 to 6.

4 WIRE CONNECTION

1. EXCITATION -
2. EXCITATION +
3. Connect with terminal 2.
4. Connect with terminal 1.
5. OUTPUT -
6. OUTPUT +

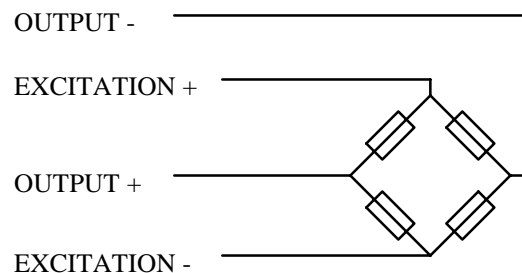

6 WIRE CONNECTION

1. EXCITATION -
2. EXCITATION +
3. SENSE +
4. SENSE -
5. OUTPUT -
6. OUTPUT +

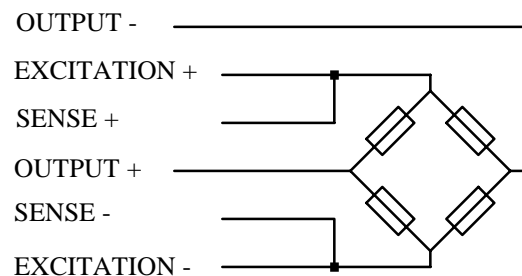

Connect the shield of the cable to ground terminal (Terminal T of Terminal board MA)

DIGITAL INPUT (TERMINAL BOARD MC)

The digital input are activated when a 24 Vcc power is applied
 To activate a digital input connect the respective terminal with the positive terminal 13 of the terminal board MC

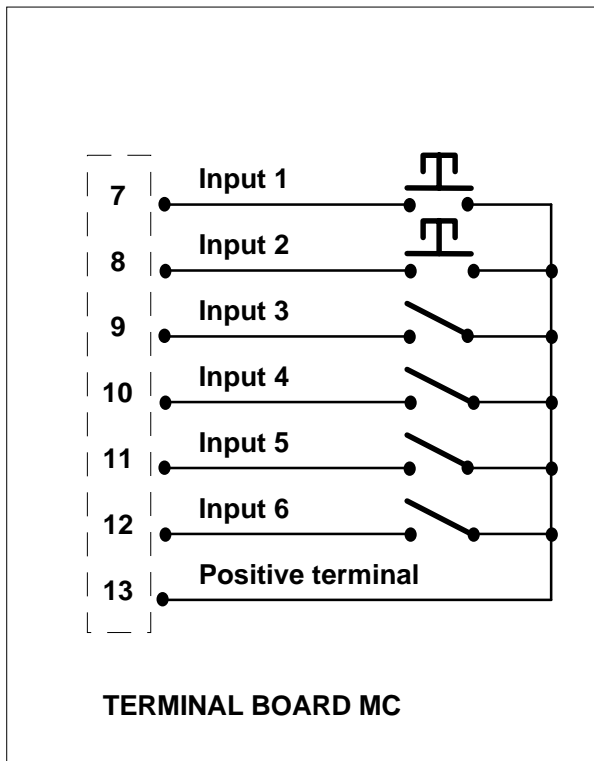

DIGITAL OUTPUT (TERMINAL BOARD MB)

The capacity of each relè is 0,5° / 24 Vcc 115 Vac

TERMINAL BOARD MB

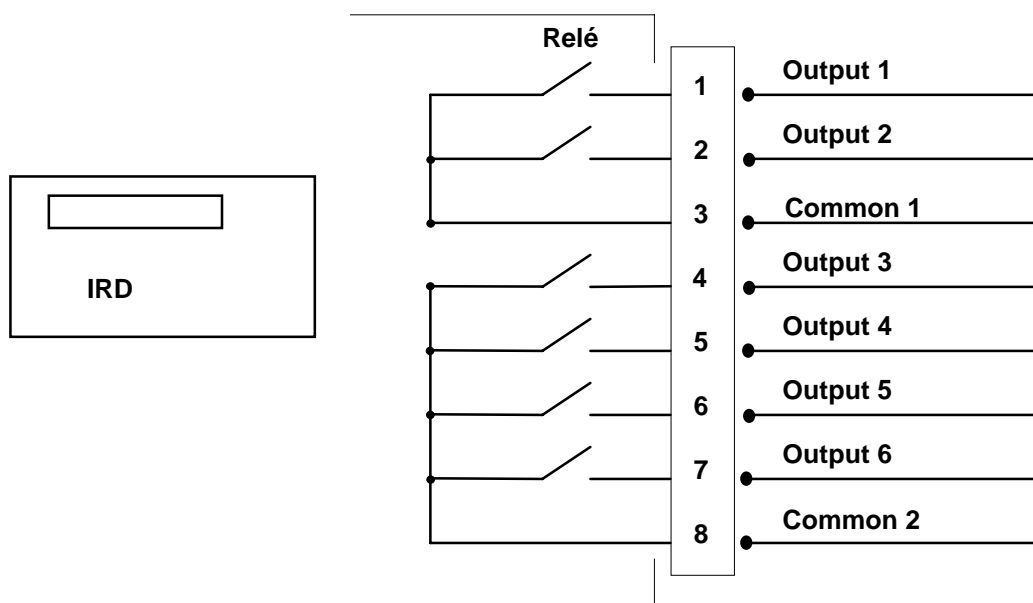

SERIAL CONNECTION RS 232 WITH PERSONAL COMPUTER

- The maximum length of the cable should be 15 m (EIA RS232C)

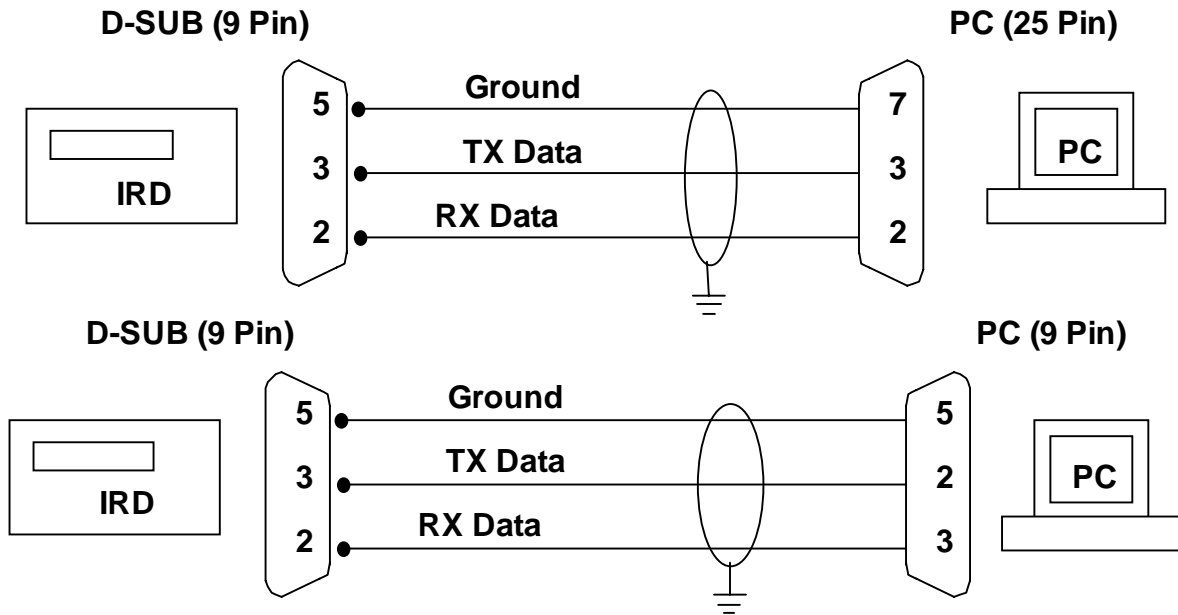

SERIAL CONNECTION RS485 (Optional)

This kind of connection give the possibilità to connect more than one IRD to the same MASTER unit (a Personal Computer) using only one serial line and obviously only one serial output on the PC. The maximum number of the units is 32.

CONNECTION WITH RS232/RS485 CONVERTER

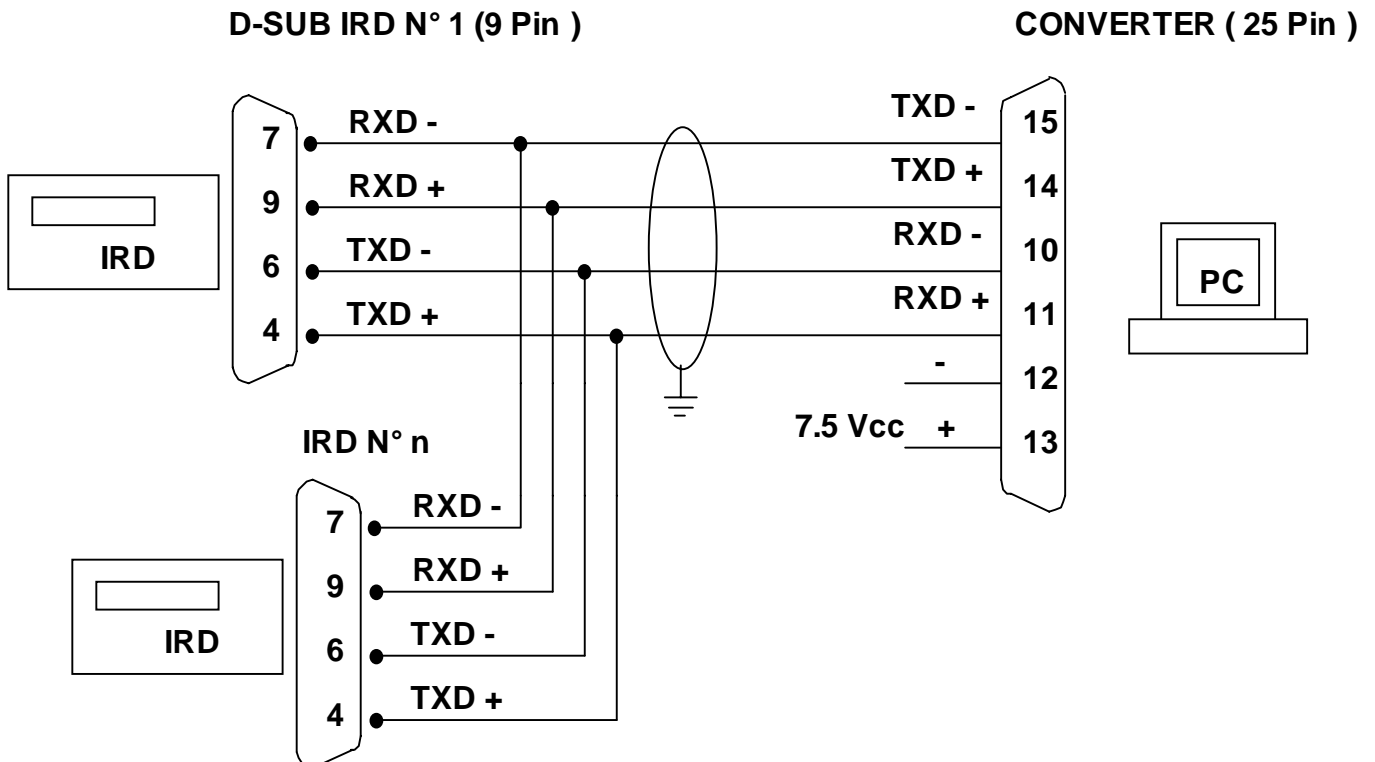

SERIAL CONNECTION RS422 WITH WEIGHT REPEATER OR PC (Optional)

Through serial interface RS422 it is possible to do connections for long distances

CONNECTION RS422 WITH WEIGHT REPEATER H60

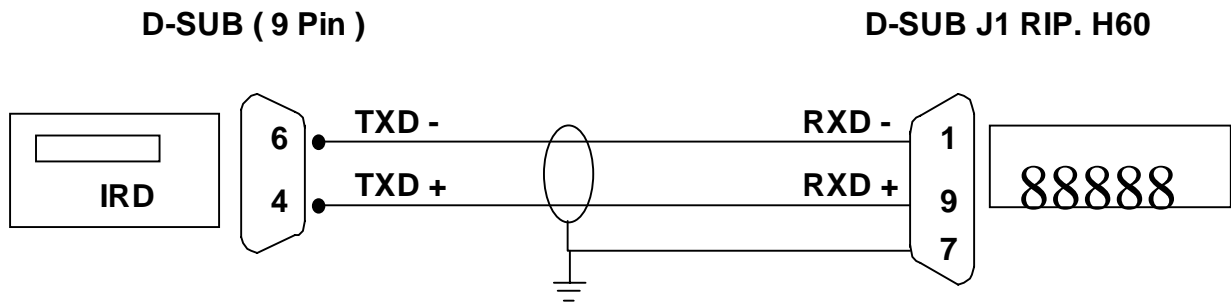

CONNECTION RS422 WITH WEIGHT REPEATER H100

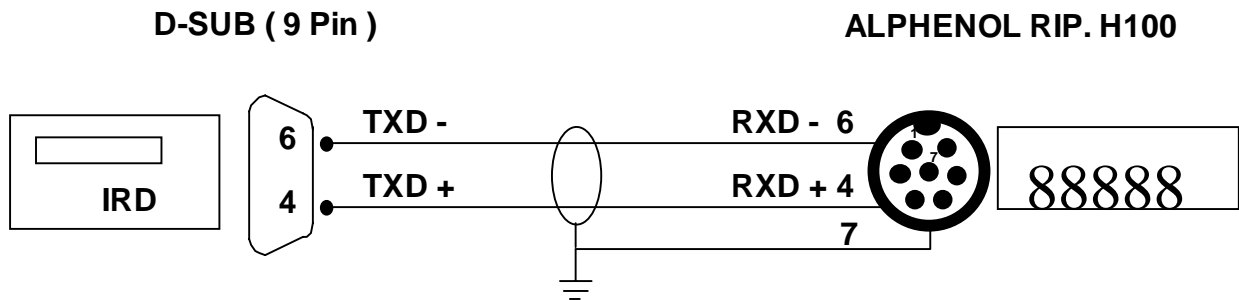

CONNECTION WITH SERIAL CONVERTER RS422/RS232

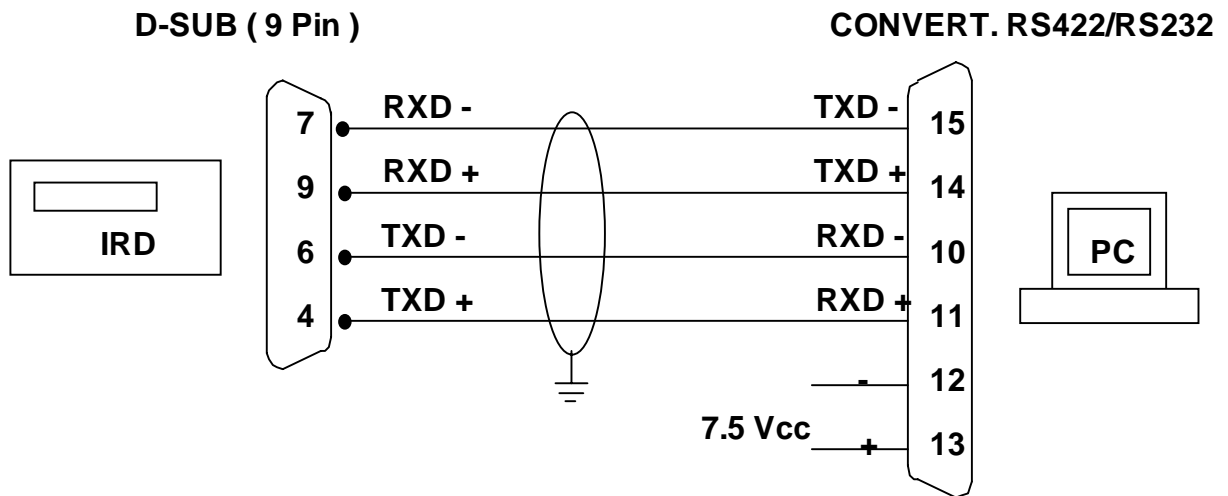

SERIAL CONNECTION WITH PRINTER

The printer should have to be set with these selections :

- **Baud Rate:** 9600 bps
- **Data bit :** 8 bit.
- **Start Bit :** 1 bit.
- **Parità Bit :** 0 bit.
- **Stop Bit :** 1 bit.
- **Handshaking:** DTR.

COM IRD (9 Pin)

D-SUB (25 Pin)Printer

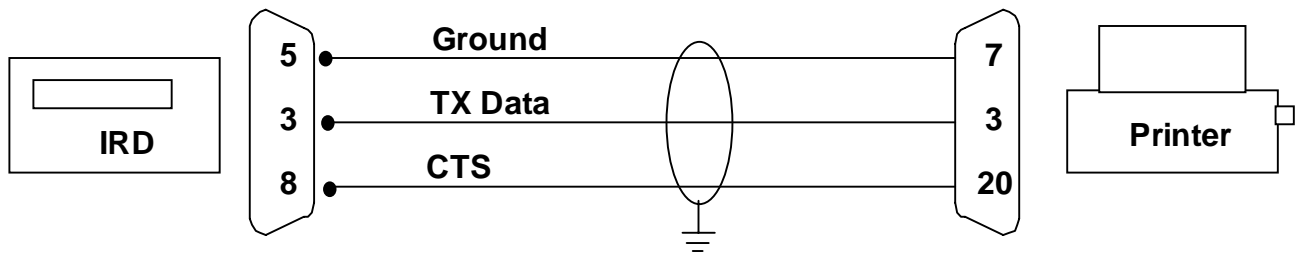

ANALOG OUTPUT

Characteristic:

- Analog output in voltage: range from 0 to 10 Volt, minimum load 10KΩ
- Analog output in current: range from 0 to 20 mA or from 4 to 20 mA. Maximum load 400Ω.

CONNECTION ON TERMINAL BOARD MC

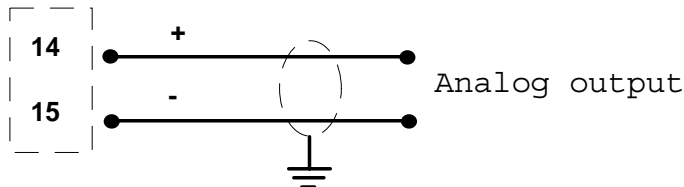

SET OF ANALOG OUTPUT

It is possible to choose from voltage to current through a jumper hardware on the mother board
 E' tuttavia possibile modificare tale impostazione spostando un ponticello presente sulla scheda base dello strumento (S118).

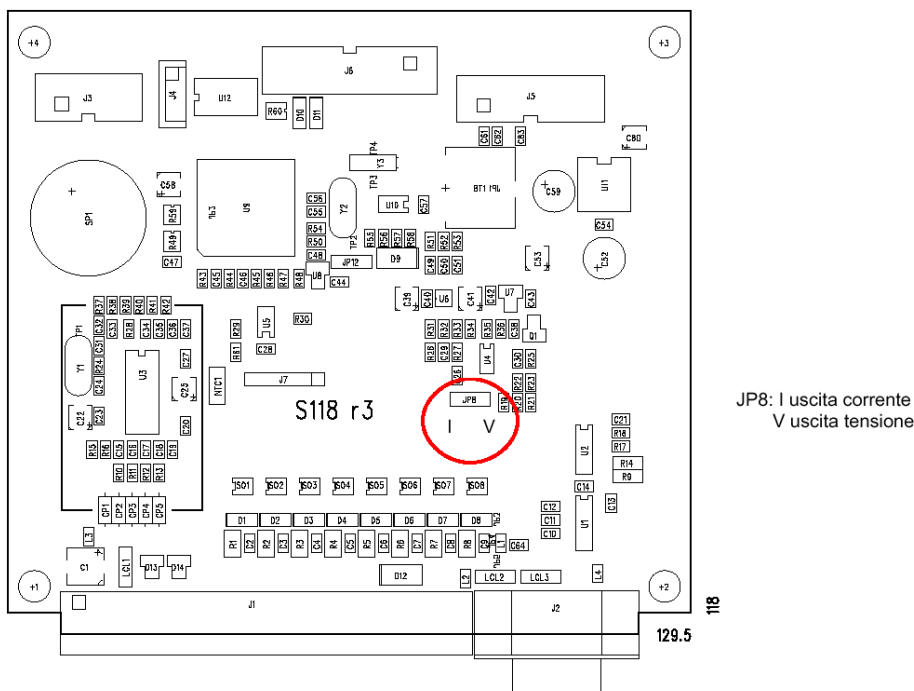

SERIAL CONNECTION WITH OUTPUT BCD

D-SUB (9 Pin)

BCD Board (9 Pin)

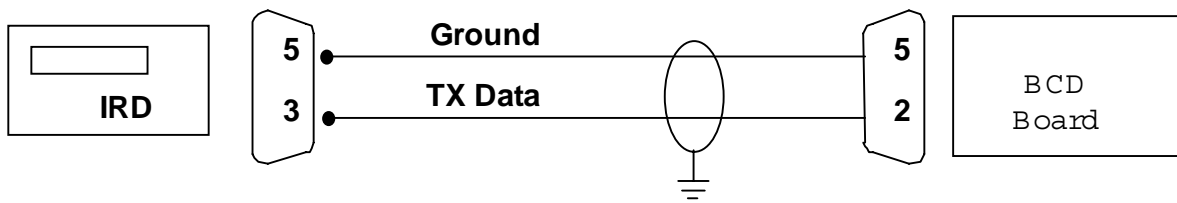

CONNECTIONS

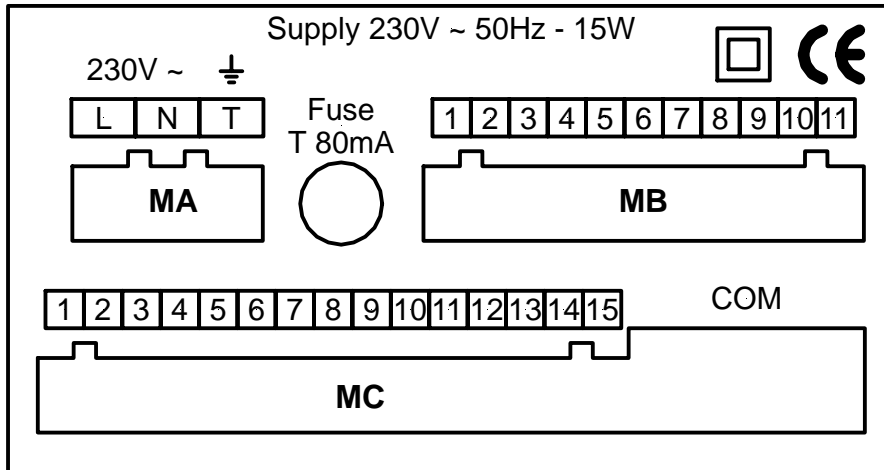

CONNECTIONS

NUM.	Power supply 3P step 7.5	Terminal MB 11P step 5.08	Terminal 15P step 5.08	D-SUB 9P
1	Line 230V~	Out 1	Excitation -	
2	Neutral 230V~	Out 2	Excitation +	(RX) RS232 (COM1)
3	Ground	Common out	Sense +	(TX) RS232 (COM1)
4		Out 3	Sense -	(TX +) RS422 (COM2)
5		Out 4	Output -	GND (COM1)
6		Out 5	Output +	(TX -) RS422 (COM2)
7		Out 6	Input 1	(RX-) RS422 (COM2)
8		Common out	Input 2	(CTS) RS232 (COM1)
9			Input 3	(RX+) RS422 (COM2)
10			Input 4	
11			Input 5	
12			Input 6	
13			Common input	
14			Out analog + (Input 7)	
15			Out Analog - (Input 8)	

Odeca s.r.l.
Via dell'Industria,20
21044 Cavaria – VA
tel. 0331.219156
0331.218844
fax. 0331.218366
<http://www.odecasrl.com>
e-mail : odecasrl@tin.it